

2 BUS Adapter & Network Adapter

CN-8011 Modbus-RTU Bus Adapter

1 Module Overview

CN-8011 Modbus-RTU bus adapter supports standard Modbus-RTU communication, it supports function code of 01/02/03/04/05/06/15/16/23, and this device could monitor the IO module communication state in real time.

2 Technical Parameter

Adapter Hardware Parameter	
System Power	Nominal:24Vdc, Range: 9-36Vdc Reverse Protection: YES
Power Consumption	30mA@24Vdc
Internal Bus Supply Current	Max: 2.5A@5VDC
Isolation	System Power to Field Power Isolation
Power Supply	Nominal:24Vdc, Range:22-28Vdc
Field Power Current	Max. DC 8A
IO Modules Supported	32 pcs
Wiring	Max.1.0mm ² (AWG 17)
Mounting Type	35mm DIN-Rail
Size	115*51.5*75mm
Weight	130g
Environment Specification	
Operation Temperature	-40~85°C
Operation Humidity	5%-95% (No Condensation)
Ingress Protection Rating	IP20
Modbus-RTU Parameter	
Protocol	Modbus-RTU/ASCII
Function Code	01 / 02 / 03 / 04 / 05 / 06 / 15 / 16
Baud Rate	2400~115200bps
Station No.	1~63(Dial-code switch configuration),64~247(Software configuration)
Interface	5 Pin screw terminal
Data Bits	7, 8
Parity Checking	None, Even, ODD
Stop Bit	1, 2
Max. bus length	1200m (RS485, 2400 baud rate)

Terminal resistance and offset resistance	DIP switch configuration
---	--------------------------

3 Hardware Interface

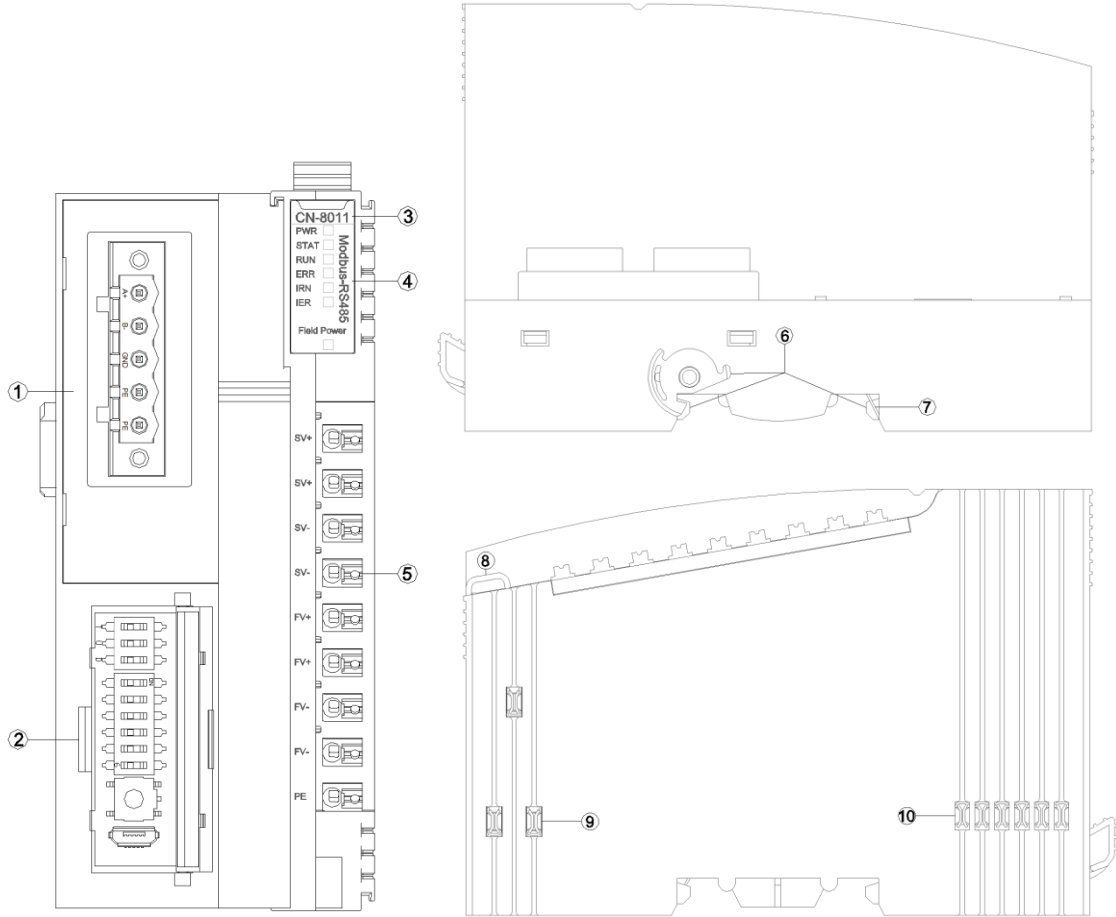

- ① RS485 port
- ② Config Interface
- ③ Module type
- ④ LED Indicator
- ⑤ Wiring Terminal
- ⑥ Buckle
- ⑦ Grounding Spring Sheet
- ⑧ Fixed Wiring Harness
- ⑨ Field Power
- ⑩ Internal Bus

3.1 RS485 Interface

Modbus RS485 port is 5 Pin screw terminals and its Pin definition is as below:

Pin	Definition	Description
1	A+	RS485 A+
2	B-	RS485 B-
3	SGND	Signal Grounded
4	Shield	Earthing of Shield
5	PE	Protect Earthing

It is recommended to use cables with cores smaller than 1mm ?

The cold-pressed terminal parameters are as follows:

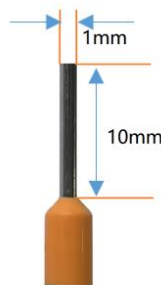

3.2 Configuration Interface

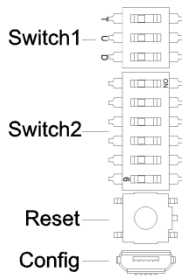

Switch1: DIP switch used to set the terminal resistance, pull up and down resistance. T: terminal resistance, U: pull up resistance, D: pull down resistance.



The Switch2: DIP switch used to set the adapter module address. It is set by an 8-bit binary hardware dial - code switch, and each Modbus adapter has a unique station address (1~63).

(Special note: When the address needs to be set beyond 63, the address should be dialed to set it to 0, and the station address should be set in IO Config software)



Reset: Module reset button, long pressing the button for more than 5 seconds and all parameters of the module will be restored to the default value. When the Reset button is activated, a green indicator will light up in the upper left corner of the button.

Config: configured ports, it is standard MicroUSB interface for configuring device parameters and firmware upgrades.

3.3 LED Indicator

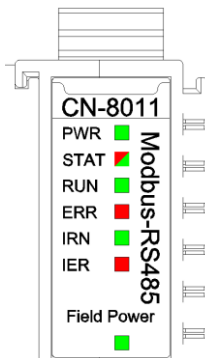

PWR Power State (GREEN)	Definition
ON	System Power Normal
OFF	System Power Failure
STAT Module State (RED/GREEN)	Definition
Double Flash (RED)	Module Soft Restarted by Hard-Fault
ON(GREEN)	Running
Single Flash (GREEN)	Stopping
Flash(2.5Hz) (RED/GREEN)	Boot Mode
Flash(10Hz) (RED/GREEN)	Firmware Updating
RUN Network State (GREEN)	Definition
OFF	No data exchanging.
Flash	Modbus data exchanging
ERR Network Error (RED)	Definition
OFF	Modbus data exchanging normal

ON	Modbus data exchanging failure
IRN IO Run (GREEN)	Definition
ON	IO initialization normal
OFF	IO initialization failure
IER IO Error (RED)	Definition
OFF	IO communication normal
Double Flash	IO communication failure
Field Power State (GREEN)	Definition
ON	Field Power Normal
OFF	Field Power Failure

4 Wiring

Please note when wiring: for the internal construction, two terminals of SV+ have been short-connected, two terminals of SV- have been short-connected, two terminals of FV+ have been short-connected, and two terminals of FV- have been short-connected. For external it only needs to access one system power supply and one field power supply.

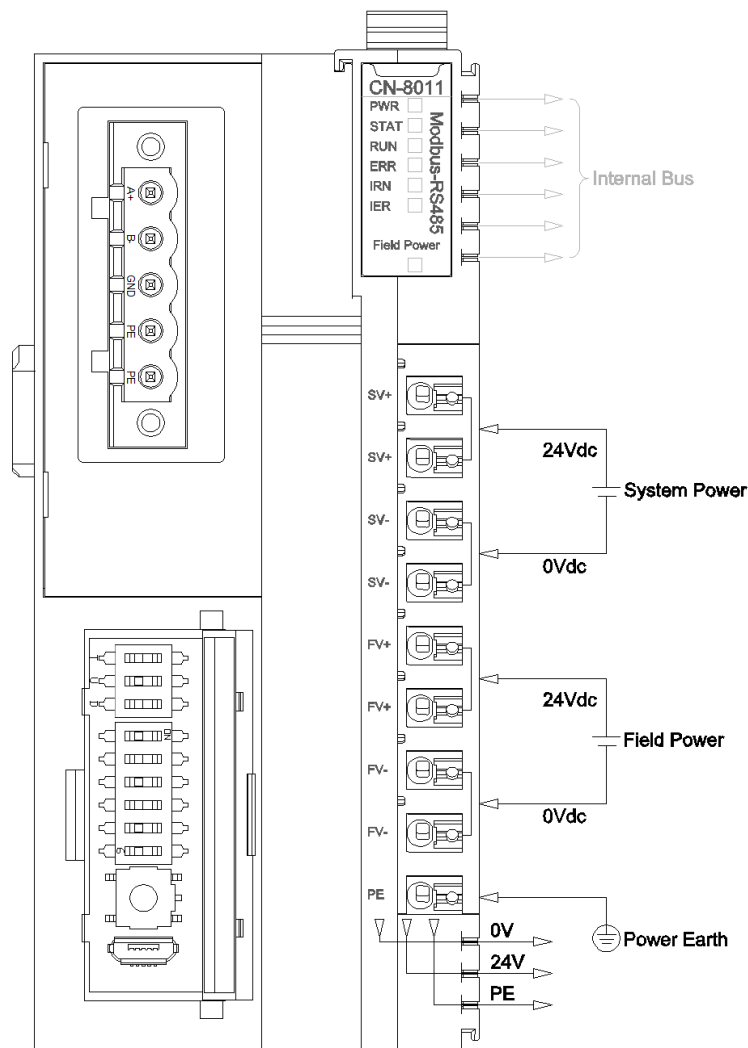

5 Process data definition

5.1 Adapter process data definition

Modbus-RTU Adapter itself has no input-output process data.

5.2 IO Module process data mapping

The network adapter reads and writes input and output process data of IO module in real time through the internal bus, and its data mapping model is shown as follow:

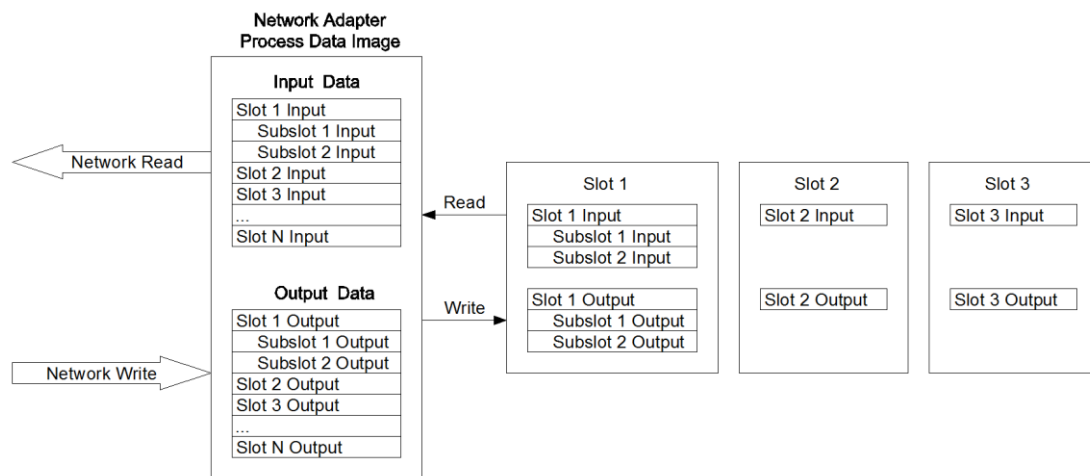

Modbus address mapping table varies according to module combination, and detailed address mapping table could be viewed through IO Config – the configuration software.

6 Configuration Parameter Definition

Configuration Parameter								
Bit No	Bit 7	Bit 6	Bit 5	Bit 4	Bit 3	Bit 2	Bit 1	Bit 0
Byte 0						Fault Action for Output	Fault Action for Input	Source of Configuration Data
Byte 1	Slave ID							
Byte 2	BaudRate							
Byte 3								
Byte 4								
Byte 5								
Byte 6		Serial Mode	Stop Bits		Parity Bits		Data Bits	
Byte 7	Char Pitch							
Byte 8	Response Delay(ms)							
Byte 9								

Data declaration:

Source of Config Data: Parameter configuration mode (Default: 0)

0: Configuration Software

Fault Action for Input: Input fault handling mode, when IO module is offline, the adapter will process IO module input data according to this mode. (Default: 0, Hold Last Input Value)

0: Hold Last Input Value

1: Clear Input Value

Fault Action for Output: Output fault handling mode, when the IO module is offline, the adapter will process the IO module output data according to this mode. (Default: 1, Clearing Output Value)

0: Hold Last Output Value

1: Clearing Output Value

Slave ID: Modbus slave ID, hardware dial code or software configuration, 1-247

Baud Rate: Serial port baud rate, (Default: 2, 9600bps)

0: 2400bps

- 1: 4800bps
- 2: 9600bps
- 3: 14400bps
- 4: 19200bps
- 5: 38400bps
- 6: 57600bps
- 7: 115200bps

Data Bits: data bits, (default: Bit 1, 8)

- 0: Bit 7
- 1: Bit 8

Parity Bits: Parity Checking, (default: 0, no parity)

- 0: None
- 1: ODD
- 2: EVEN

Stop Bits: stop bits, (default: Bit 0, 1)

- 0: Bit 1
- 1: Bit 2

Serial Mode: Serial port mode (default: 0, RTU)

- 0: RTU
- 1: ASCII

Char Pitch: Character Pitch is the detection time of frame interval when receiving a message (T is the time of single character transmission, related to baud rate) (default: 2, 5 characters)

- 0: 1.5 characters
- 1: 3.5 characters
- 2: 5 characters
- 3: 10 characters
- 4: 20 characters

5: 50 characters

6: 100 characters

7: 200 characters

Response Delay(ms): Reply delay time from Slave, self-defined, default 10ms, effective range: 0-65535.

A Dimension drawing

