

CT-3168 8 channels Voltage Input

0~5/0~10/±5/±10VDC, 15Bit/16 Bit

1 Module features

- ◆ the module supports 8 channels of voltage signal input
- ◆ the module could collect 0~5VDC, 0~10VDC, ±5VDC, ±10VDC, with a 15-bit or 16-bit resolution
- ◆ the module carries with 8 analog input channel LED indicator
- ◆ the module input signal is a single ended common grounding input
- ◆ filter time could be set
- ◆ channels could be disabled independently

2 Technical Parameters

General parameters	
Power	Max.100mA@5.0Vdc
Isolation	I/O to internal bus: opto-couple isolation (3KVrms)
Field Power	Not used
Wiring	Max.1.0mm ² (AWG 17)
Mounting Type	35mmDIN-Rail
Size	115*14*75mm
Weight	65g
Environment Specification	
Operational Temperature	-40~85°C
Operational Humidity	5%~95% RH(No Condensation)
Ingress Protection Rating	IP20
Input Parameter	
Channel Number	8 channel voltage input
LED Indicator	8 channel input indicators
Input Voltage Range	0~5VDC、0~10VDC、±5VDC、±10VDC
Resolution	15Bit/16Bit
Accuracy	±0.3% @25°C ±0.5@-40~85°C
Sampling Speed	1ms/8 channels
Output Impedance	1MΩ
Common Terminal	Common Grounding Input

3 Hardware Interface

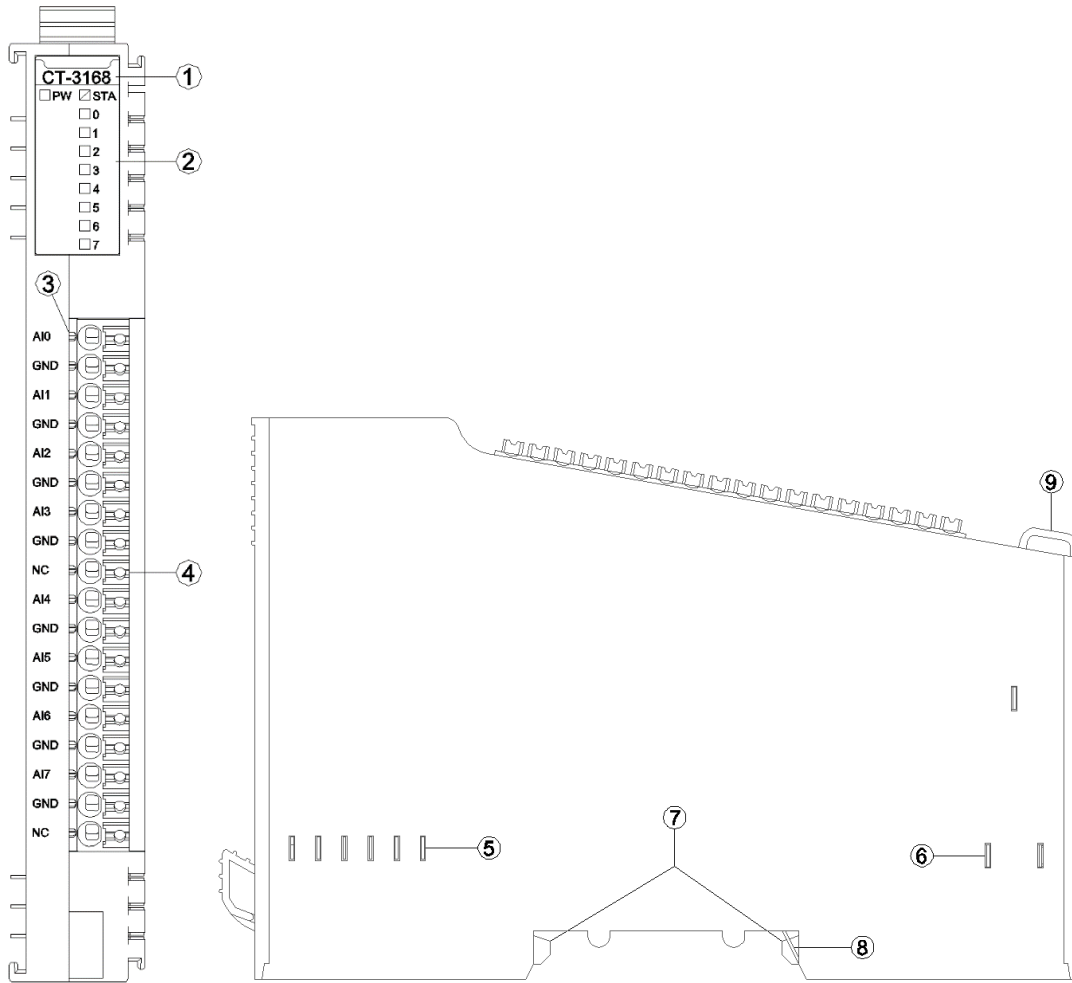

- ① Module Type
- ② State indicator
- ③ N/A
- ④ Wiring Terminal and identification
- ⑤ Internal Bus
- ⑥ Field Power
- ⑦ Buckle
- ⑧ Grounding Spring Sheet
- ⑨ Fixed Wiring Harness

3.1 LED indicator definition

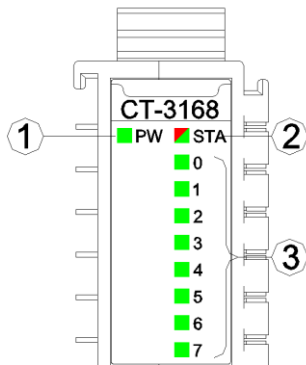

- ① Power LED indicator (green)
- ② Module State LED indicator (red/green)
- ③ Input channel LED indicator (green)

PW POWER STATE (GREEN)	Definition
ON	Internal bus Power Normal
OFF	Internal bus Power Failure
STA MODULE STATE (RED/GREEN)	Definition
Green slow flash (2.5Hz)	Module internal bus is not started
Red slow flash (2.5Hz)	Module internal bus offline
ON (GREEN)	Operation normal
Flash(2.5Hz) (RED/GREEN)	Upgrading mode
Flash(10Hz) (RED/GREEN)	Firmware Update
Double Flash (RED)	Module Exception has been soft-restarted
0-7 channel LED indicator (GREEN)	Definition
ON	Input signal exceeds 0.15V or -0.15V
OFF	Invalid input signal

3.2 Terminal definition

Terminal Number	Definition	Description
1	AI0	Signal Input CH0
2	GND	
3	AI1	Signal Input CH1
4	GND	
5	AI2	Signal Input CH2
6	GND	
7	AI3	Signal Input CH3
8	GND	
9	NC	Not Connected
10	AI4	Signal Input CH4
11	GND	
12	AI5	Signal Input CH5
13	GND	
14	AI6	Signal Input CH6
15	GND	
16	AI7	Signal Input CH7
17	GND	
18	NC	Not Connected

It is recommended to use cables with cores smaller than 1mm ?

The cold-pressed terminal parameters are as follows:

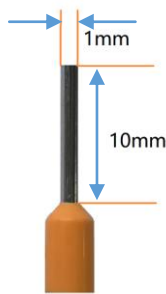

4 Wiring

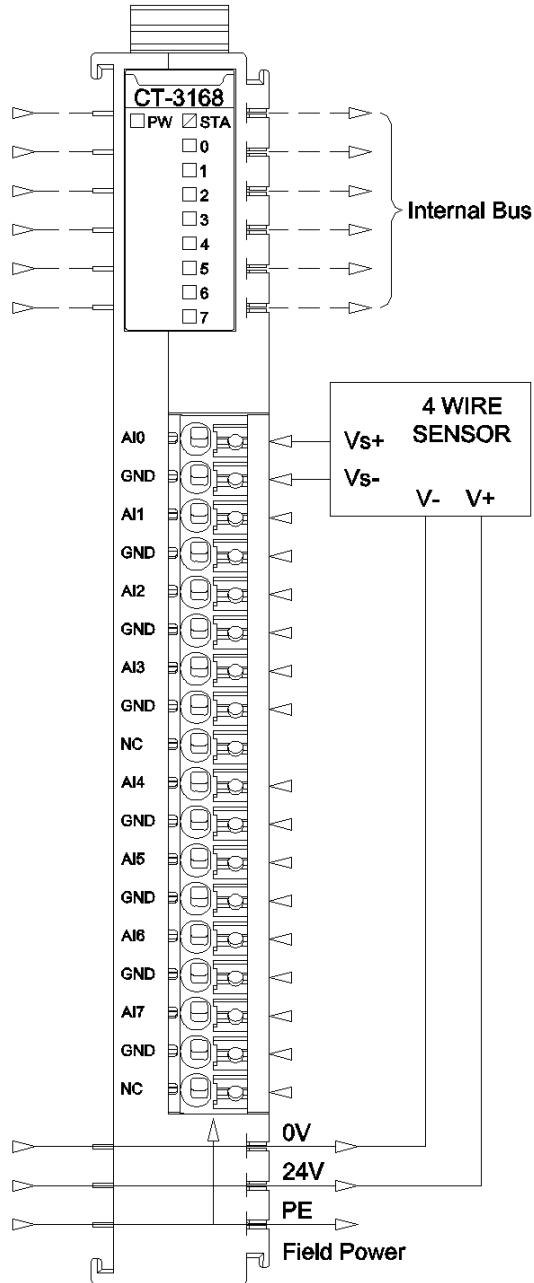

5 Process data definition

Input Data								
Bit No	Bit 7	Bit 6	Bit 5	Bit 4	Bit 3	Bit 2	Bit 1	Bit 0
Byte 0	Analog Input Data (CH 0)							
Byte 1								
Byte 2	Analog Input Data (CH 1)							
Byte 3								
Byte 4	Analog Input Data (CH 2)							
Byte 5								
Byte 6	Analog Input Data (CH 3)							
Byte 7								
Byte 8	Analog Input Data (CH 4)							
Byte 9								
Byte 10	Analog Input Data (CH 5)							
Byte 11								
Byte 12	Analog Input Data (CH 6)							
Byte 13								
Byte 14	Analog Input Data (CH 7)							
Byte 15								

5.1 Process data definition (standard mode)

Data Declaration:

Analog Input Data (CH0-7): Voltage input data value

Process data definition (8AI)						
Voltage (0-5V)	Voltage (0-10V)	Voltage ($\pm 5V$)	Voltage ($\pm 10V$)	Decimal	Hex	Range
>5.06	>10.12	>5.06	>10.12	32767	0x7FFF	Overflow
5.06	10.12	5.06	10.12	27979	0x6D4B	Exceeds the upper limit
5V+0.1808mv	10V+0.3617mv	5V+0.1808mv	10V+0.3617mv	27649	0x6C01	
5	10	5	10	27648	0x6C00	Rated range
.	
.	
2.5	5	2.5	5	13824	0x3600	
.	
.	
0	0	0	0	0	0x0000	
/	/	
/	/	
/	/	-2.5	-5	-13824	0XCA00	
/	/	
/	/	
/	/	-5	-10	-27648	0x9400	
/	/	-5V-0.1808mv	-10V-0.3617mv	-27649	0x93FF	Exceeds the lower limit
/	/	-5.06	-10.12	-27979	0x92B5	
/	/	-5.06<	-10.12<	-32768	0x8000	Underflow

5.2 Process data definition (special mode)

Process data definition (8AI)						
Voltage (0-5V)	Voltage (0-10V)	Voltage ($\pm 5V$)	Voltage ($\pm 10V$)	Decimal	Hex	
5	10	5	10	32767	0x7FFF	
.	
.	
2.5	5	2.5	5	16383	0x3FFF	
.	
.	
0	0	0	0	0	0x0000	
/	/	
/	/	
/	/	-2.5	-5	-16384	0xC000	
/	/	

/	/
/	/	-5	-10	-32768	0x8000

6 Configuration parameters definition

Configuration Parameters								
Bit No	Bit 7	Bit 6	Bit 5	Bit 4	Bit 3	Bit 2	Bit 1	Bit 0
Byte 0	Reserved						Range_ Mode	16Bit Data Format
Byte 1	Voltage Type (CH 1)			Voltage Type (CH 0)				
Byte 2	Voltage Type (CH 3)			Voltage Type (CH 2)				
Byte 3	Voltage Type (CH 5)			Voltage Type (CH 4)				
Byte 4	Voltage Type (CH 7)			Voltage Type (CH 6)				
Byte 5	Filtering Time (CH0)							
Byte 6								
Byte 7	Filtering Time (CH1)							
Byte 8								
Byte 9	Filtering Time (CH2)							
Byte 10								
Byte 11	Filtering Time (CH3)							
Byte 12								
Byte 13	Filtering Time (CH4)							
Byte 14								
Byte 15	Filtering Time (CH5)							
Byte 16								
Byte 17	Filtering Time (CH6)							
Byte 18								
Byte 19	Filtering Time (CH7)							
Byte 20								
Byte 21	Reserved							
...								
Byte 29								

Data Declaration:

16Bit Data Format: Sequence of 16-bit data byte transmission (Default:0)

0: A_B。

1: B_A。

Range_Mode: Process data mode (default: standard mode)

Standard mode: same with Siemens process data definition

Special mode: max range of the hardware

Voltage Type(CH 0-7): Input voltage type (Default:3)

0: disabled

1: 0~5Vdc

2: -5~5Vdc

3: 0~10Vdc

4: -10~10Vdc

Filtering Time(CH0-CH7): The input filtering time of the channel, in ms.

(Default: 10)

A Dimension drawing

