

CN-8032 Profinet Network Adapter

1 The module overview

The CN-8032 Profinet network adapter supports standard Profinet IO Device Communication. The adapter supports MRP media redundancy, and it could realize ring network redundancy. And it supports RT/IRT real-time and synchronous communication mode, with its RT real-time communication minimum period of 1ms and IRT synchronous communication minimum period of 250us. The adapter supports a maximum input of 1440 bytes, a maximum output of 1440 bytes, and the number of the extended IO modules it supports is 32.

2 Technical Parameters

Hardware Specification	
System Power	Nominal: 24Vdc, Range: 9-36Vdc Protection: Overcurrent Protection, Reverse Protection: YES
Power Consumption	110mA@24Vdc
Current Output	Max:2A@5Vdc
Isolation	System Power to Field Power Isolation
Field Power	Nominal: 24Vdc, Range: 22-28Vdc
Field Power Current	Max DC 8A
IO Modules Supported	32 pcs
Wiring	Max.1.0mm ² (AWG 17)
Mounting Type	35mm DIN-Rail
Size	115*51.5*75mm
Weight	130g
Environment Specification	
Operational Temperature	-40~85°C
Operational Humidity	5%-95% (No Condensation)
Ingress Protection Rating	IP20
Profinet Parameter	
Protocol	Profinet IO Device
I/O Data Size	Input Max 1440 Bytes, Output Max 1440 Bytes
RT	Supported, Min.1ms
IRT	Supported, Min.250us
MRP	Supported
MRPD	Not supported
Network Interface	2*RJ45

Speed	10/100Mbps, MDI/MIDX, Full-Duplex
Max bus distance	100m
Profinet Device Name	DIP switch setting or Profinet monitor modifying

Notice: The adapter does not support the MRPD (Media Redundancy for Planned Duplication) function, so the MRP and IRT functions cannot be used simultaneously.

3 Hardware Interface

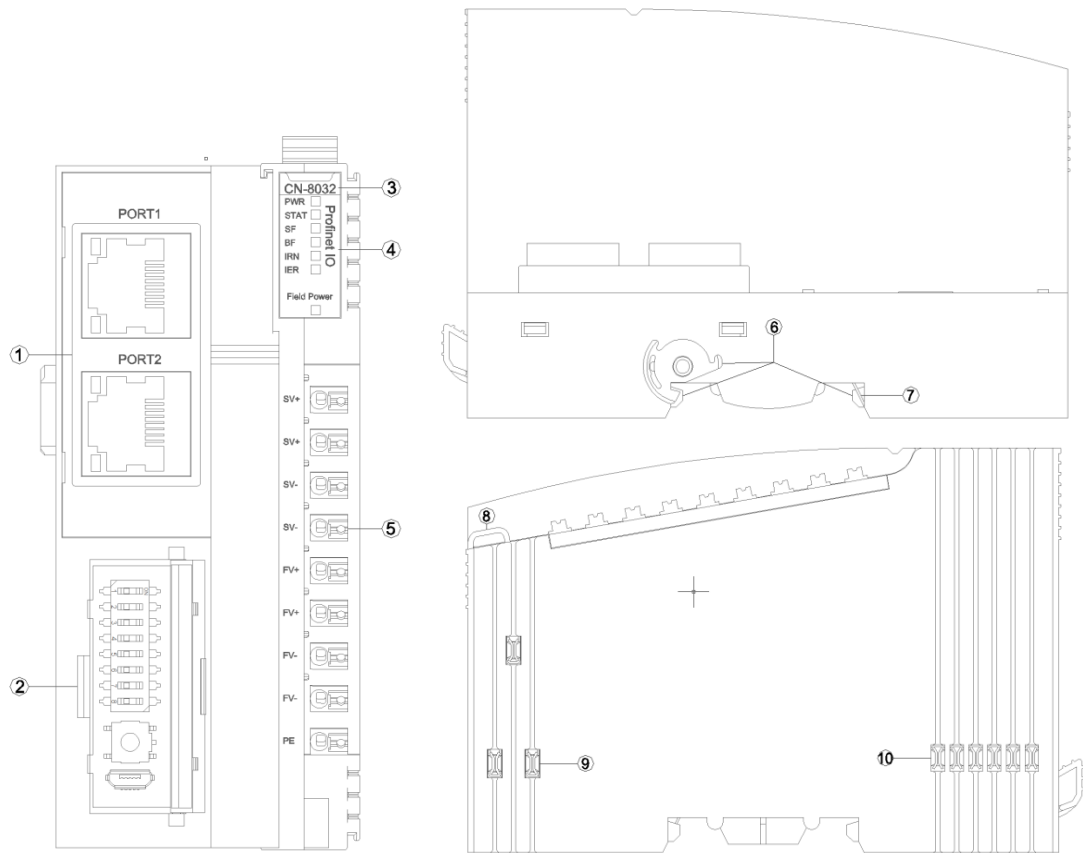

- ① Network Interface
- ② Config Interface
- ③ Module Type
- ④ LED Indicator
- ⑤ Wiring Terminal
- ⑥ Buckle
- ⑦ Grounding Spring Sheet
- ⑧ Fixed Wiring Harness
- ⑨ Field Power
- ⑩ Internal Bus

3.1 Network Interface

PORT1 and PORT2 are both Profinet communication port, and support switch function with 10Mbps and 100Mbps data rates, MDI/MID-X auto crossover.

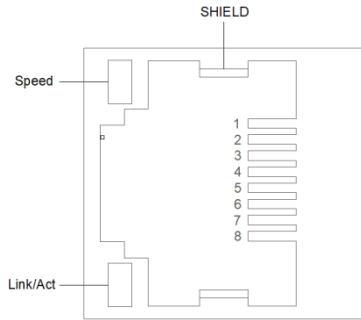

Speed: Network Speed LED (Green)

ON: 100Mbps

OFF: 10Mbps

Link/Act: Link State、Active State(Orange)

ON: Link UP

OFF: Link DOWN

Flash: Active

SHIELD: RJ45 Shield Interface

RJ45 Pin definition

Pin	Definition	Description
1	TD+	Transmitter Signal Positive
2	TD-	Transmitter Signal Negative
3	RD+	Receiver Signal Positive
4	--	--
5	--	--
6	RD-	Receiver Signal Negative
7	--	--
8	--	--

3.2 Configuration Interface

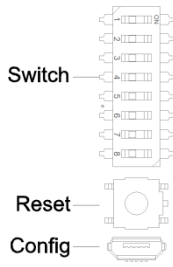

Switch: The DIP switch is used to set the name of Profinet device.

When the DIP switch value is 0, the device default name is cn8032-addr, and it could use Profinet monitor to set the device name online.

When the dial-code switch value is not 0, the device name is determined by the value of the DIP switch. The relationship between the device name and the dial value is shown in the following table:

Switch Bit Number(ON:1,OFF:0)								Switch Value	Profinet Deice Name
1	2	3	4	5	6	7	8		
0	0	0	0	0	0	0	0	0	Configured By Software (Default:cn8032-addr)
1	0	0	0	0	0	0	0	1	cn8032-1
0	1	0	0	0	0	0	0	2	cn8032-2
.
0	1	0	1	0	0	0	0	10	cn8032-10
.
0	1	1	1	1	1	1	1	254	cn8032-254
1	1	1	1	1	1	1	1	255	cn8032-255
<i>Description: Factory default dial code value is 0, the device name is cn8032-addr.</i>									

Reset: Module reset button. All parameters of the module will be restored to the default value after pressing the button for more than 5 seconds. When the Reset button

is pressed, a green LED will light up in the upper left corner of the button.

Config: Configure port, a standard Micro USB interface for configuring device parameters and firmware upgrades.

Description: device parameters can be set in Profinet IO controller configuration software.

3.3 LED Indicators

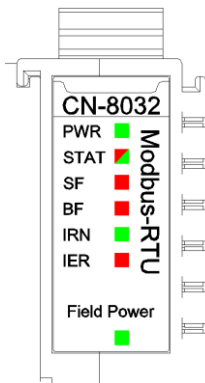

PWR Power State (GREEN)	Definition
ON	System Power Normal
OFF	System Power Failure
STAT Module State (RED/GREEN)	Definition
Double Flash (RED)	Module Soft Restart by Hard-Fault
ON(GREEN)	Operating
Single Flash (GREEN)	Stopping
Flash(2.5Hz) (RED/GREEN)	Boot Mode
Flash(10Hz) (RED/GREEN)	Firmware Update
SF System Failure (RED)	Definition
OFF	Normal
ON	System Failure, Topology Error
Flash	Led light test
Flash(10Hz)	MAC address error
BF Bus Failure (RED)	Definition
ON	Port1 and Port2 Link-Down
Flash(2.5Hz)	Offline mode
OFF	Online mode
Flash(10Hz)	MAC address error
IRN IO RUN(GREEN)	Definition
ON	IO initialization normal
OFF	IO initialization failure
IER IO Error (RED)	Definition
OFF	IO communication normal
Double Flash	IO communication failure

Field Power State (GREEN)	Definition
ON	Field Power Normal
OFF	Field Power Failure

4 Wiring

Please note when wiring: for the internal construction, two terminals of SV+ have been short-connected, two terminals of SV- have been short-connected, two terminals of FV+ have been short-connected, and two terminals of FV- have been short-connected. For external it only needs to access one system power supply and one field power supply.

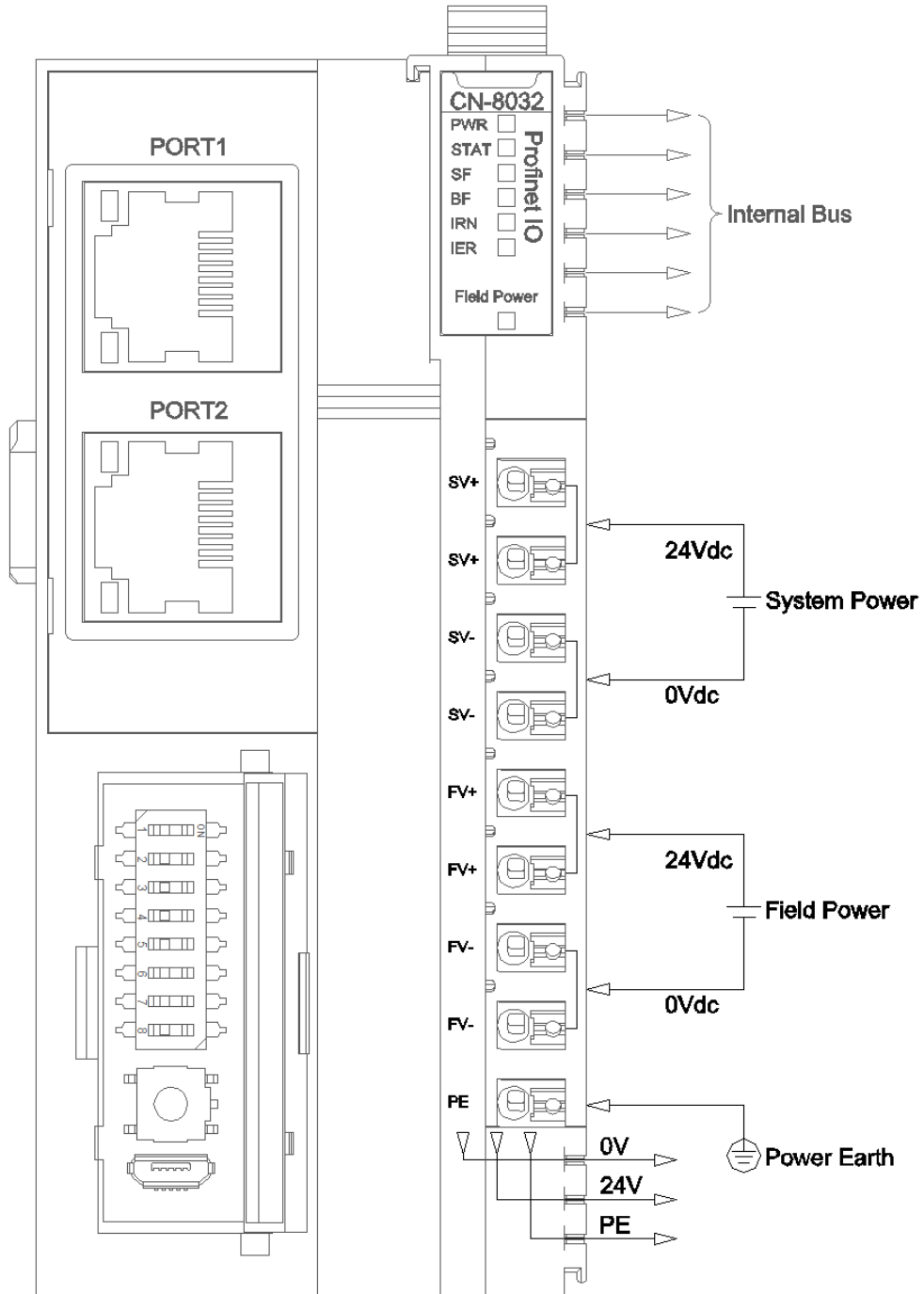

5 Process data definition

5.1 Adapter process data definition

Profinet adapter itself has no input-output process data.

5.2 IO module process data mapping

The network adapter reads and writes input and output process data of IO module in real time through the internal bus, and its data mapping model is shown as follow:

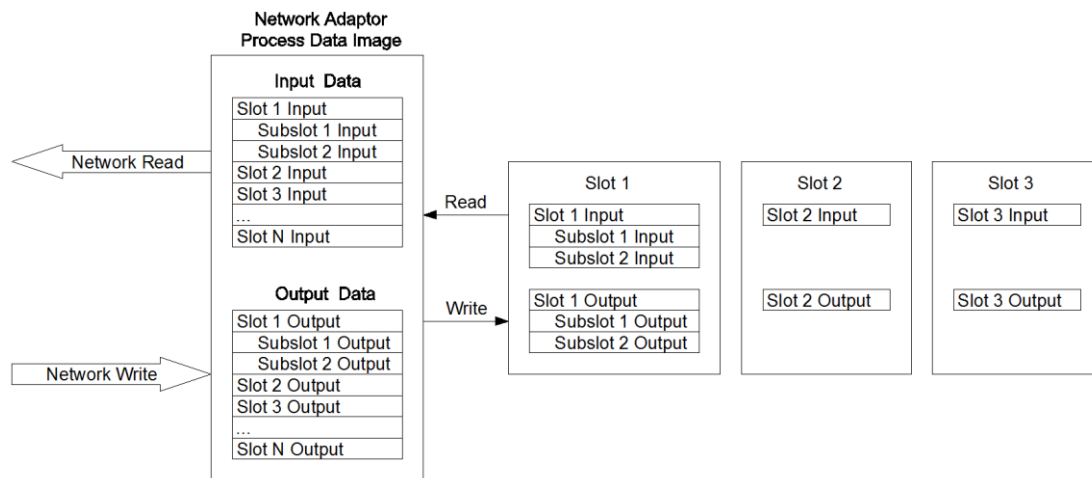

The maximum number of input bytes of the Profinet network adapter is 1440 bytes, and the maximum number of output bytes is 1440 bytes.

6 Configuration parameters definition

Configuration parameters									
Bit No	Bit 7	Bit 6	Bit 5	Bit 4	Bit 3	Bit 2	Bit 1	Bit 0	
Byte 0	Reserved					Fault Action for Output	Fault Action for Input	Source of Config Data	
Byte 1	MAC Address [0]								
Byte 2	MAC Address [1]								
Byte 3	MAC Address [2]								
Byte 4	MAC Address [3]								
Byte 5	MAC Address [4]								
Byte 6	MAC Address [5]								
Byte 7	IP Address [0]								
Byte 8	IP Address [1]								
Byte 9	IP Address [2]								
Byte 10	IP Address [3]								
Byte 11	Net Mask [0]								
Byte 12	Net Mask [1]								
Byte 13	Net Mask [2]								
Byte 14	Net Mask [3]								
Byte 15	Net Gateway [0]								
Byte 16	Net Gateway [1]								
Byte 17	Net Gateway [2]								
Byte 18	Net Gateway [3]								
Byte 19 ... Byte 82	Profinet Device Name								

Data description:

Source of Config Data: Parameter configuration mode (Default: 1)

0: Configure software

1: Field Bus

Fault Action for Input: Input fault handling mode, when IO module is offline, the adapter will process IO module input data according to this mode. (Default: 0)

0: Hold Last Input Value

1: Clearing Input Value

Fault Action for Output: Output fault handling mode, when the fieldbus is

offline the adapter will process the IO module output data according to this mode.

(Default: 1)

0: Hold Last Output Value

1: Clearing Output Value

MAC Address: MAC address, read-only attribute.

IP Address: IP address, read-only attribute.

Net Mask: Subnet mask, read-only attribute.

Net Gateway: Gateway address, read-only attribute.

Profinet Device Name: Profinet device name, read-only attribute. (Device name is determined by the DIP switch)

A Dimension drawing

