

CT-5112 2-channel encoder input/24VDC

1 Module features

- ◆ the module supports two channels of encoder input.
- ◆ each encoder channel supports A/B incremental encoder or pulse-directional encoder input.
- ◆ each encoder channel supports orthogonal A/B signal input, input voltage 24V, and it supports source and sink input.
- ◆ the incremental encoder mode supports x1/ x2 / x4 frequency multiplication mode.
- ◆ the pulse - direction mode supports nondirectional signal, pulse input only.
- ◆ each encoder channel supports 1 digital input signal with an input voltage of 5Vdc or 24Vdc.
- ◆ each encoder channel supports 1 digital output signal with an output voltage of 24Vdc.
- ◆ each encoder channel supports 1 way of 24V power output, which can be connected to the encoder for power supply.
- ◆ the module internal bus and field input adopt magnetic isolation.
- ◆ the module carries 16 LED indicators.
- ◆ the maximum input frequency of the encoder supported by the module is 1.5MHz.
- ◆ the module supports measurement function, it could detect the load speed or input signal frequency.

2 Technical parameters

General Parameters	
Power	Max.60mA@5.0Vdc
Isolation	I/O to internal bus: magnetic isolation (3KVrms)
Field Power	Nominal:24Vdc, Range:20-28Vdc
Wiring	Max.1.5mm ² (AWG 16)
Mounting Type	35mm DIN-Rail
Size	115*14*75mm
Weight	65g
Environment Specification	
Operational Temperature	-40~85°C
Operational Humidity	5%-95% (No Condensation)
Protection Class	IP20
Input Parameters	
Channel Number	2-channel encoder
LED Indicator	16 channel input LED indicator
Encoder signal voltage range	ABZ input standard 24Vdc, range $\pm 10\%$
Encoder input impedance	Internal pull-up or pull-down resistance 4.7K
Encoder filtering time	Could be set, the default value is 0.5 us
Encoder count frequency	<1.5MHz
Encoder frequency multiplication mode	x1/x2/x4
Encoder measurement function	Load speed or input signal frequency measurement
DI turn-on voltage	Min.5Vdc to Max.28Vdc
DI turn-off voltage	Max.2.7Vdc
DI turn-on current	Max.5mA/channel@28V
DI input impedance	>10.0k Ω
DI input delay	OFF to ON: Max.3ms ON to OFF: Max.2ms
DO output voltage	24V, range $\pm 10\%$
DO output current	Max.500mA
DO output sink current	Max.5uA

3 Hardware interfaces

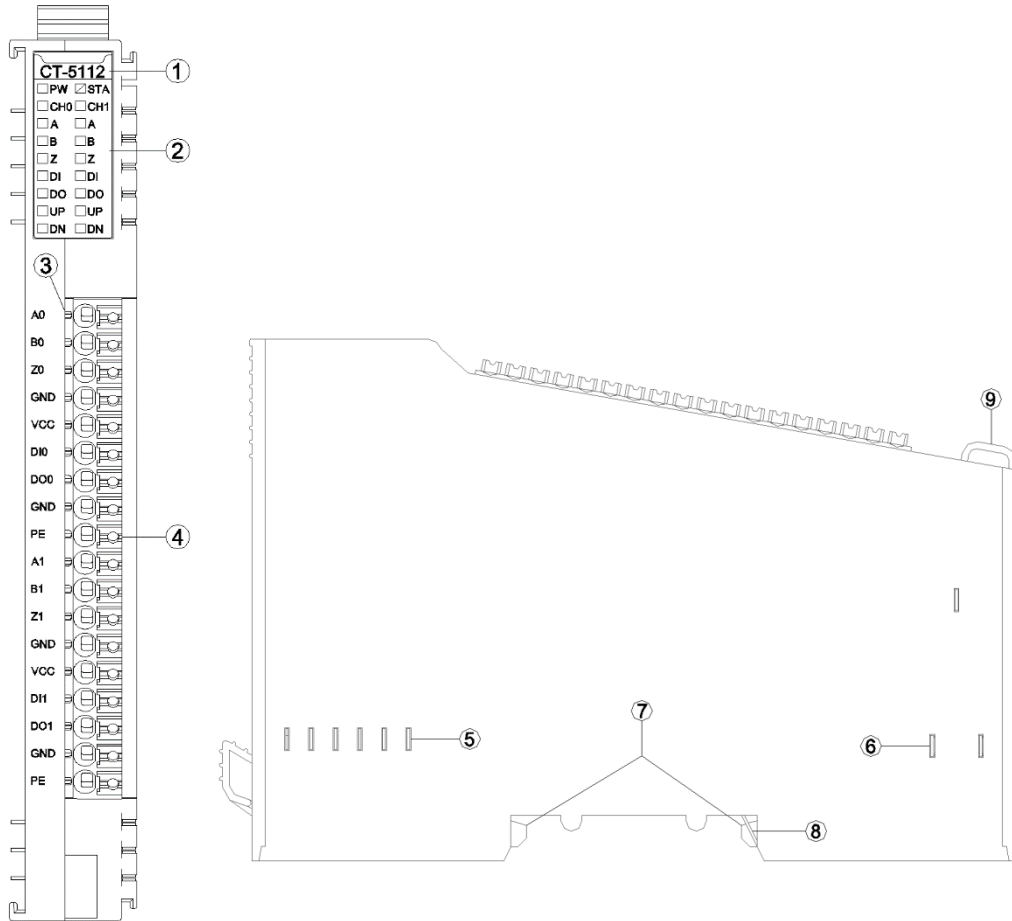

- ① Module Type
- ② State indicator
- ③ Channel indicator
- ④ Wiring Terminal and identification
- ⑤ Internal Bus
- ⑥ Field Power
- ⑦ Buckle
- ⑧ Grounding Resilient Sheet
- ⑨ Fixed Wiring Harness

3.1 LED indicator definition

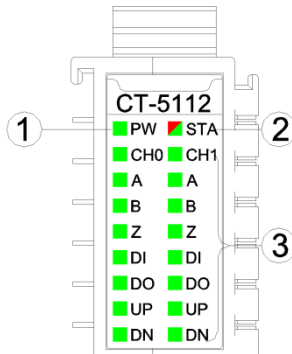

- ① Power LED indicator (green)
- ② Module State indicator LED (red/green)
- ③ Input channel indicator LED (green)

PW Power State	Definition
ON	Internal bus power supply normal
OFF	Internal bus power supply failure
STA Module State	Definition
Green slow flash (2.5 Hz)	Module internal bus is not started
Red slow flash (2.5 Hz)	Module internal bus offline
ON (GREEN)	Operation normal
Flash (2.5 Hz) (RED/GREEN)	updating mode
Flash (10 Hz) (RED/GREEN)	firmware update
Double Flash (RED)	Module exception has been soft-restarted
CH0 CH1 channel indicator LED	Definition
ON	Channel enable
A B Z Encoder signal indicator	Definition
ON	Input signal valid
OFF	Input signal invalid
DI input indicator	Definition
ON	Input signal high level
OFF	Input signal invalid
DO output indicator	Definition
ON	Output signal high level
OFF	Output signal invalid
UP indicator	Definition
ON	Encoder in positive rotation
OFF	Encoder is stationary or in contrarotation
DN indicator	Definition
ON	Encoder in contrarotation
OFF	Encoder is stationary or in positive rotation

3.2 Field channel LED indicator (Green)

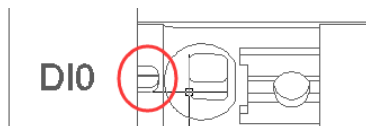

When the input signal of the input channel is valid, the corresponding field channel indicator is on (only the DI/DO/VCC wiring terminal of the encoder channel carries the indicator).

3.3 Terminal definition

Terminal Number	Symbol	Description
1	A0	CH0 encoder phase A input
2	B0	CH0 encoder phase B input
3	Z0	CH0 encoder phase Z input
4	GND	Signal ground
5	VCC	24V power output
6	DI0	CH0 digital signal input
7	DO0	CH0 digital signal output
8	GND	Signal ground
9	PE	Shield earthing
10	A1	CH1 encoder phase A input
11	B1	CH1 encoder phase B input
12	Z1	CH1 encoder phase Z input
13	GND	Signal ground
14	VCC	24V power output
15	DI1	CH1 digital signal input
16	DO1	CH1 digital signal output
17	GND	Signal ground
18	PE	Shield earthing

It is recommended to use cables with cores smaller than 1mm ?

The cold-pressed terminal parameters are as follows:

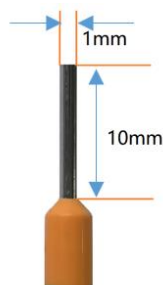

4 Wiring

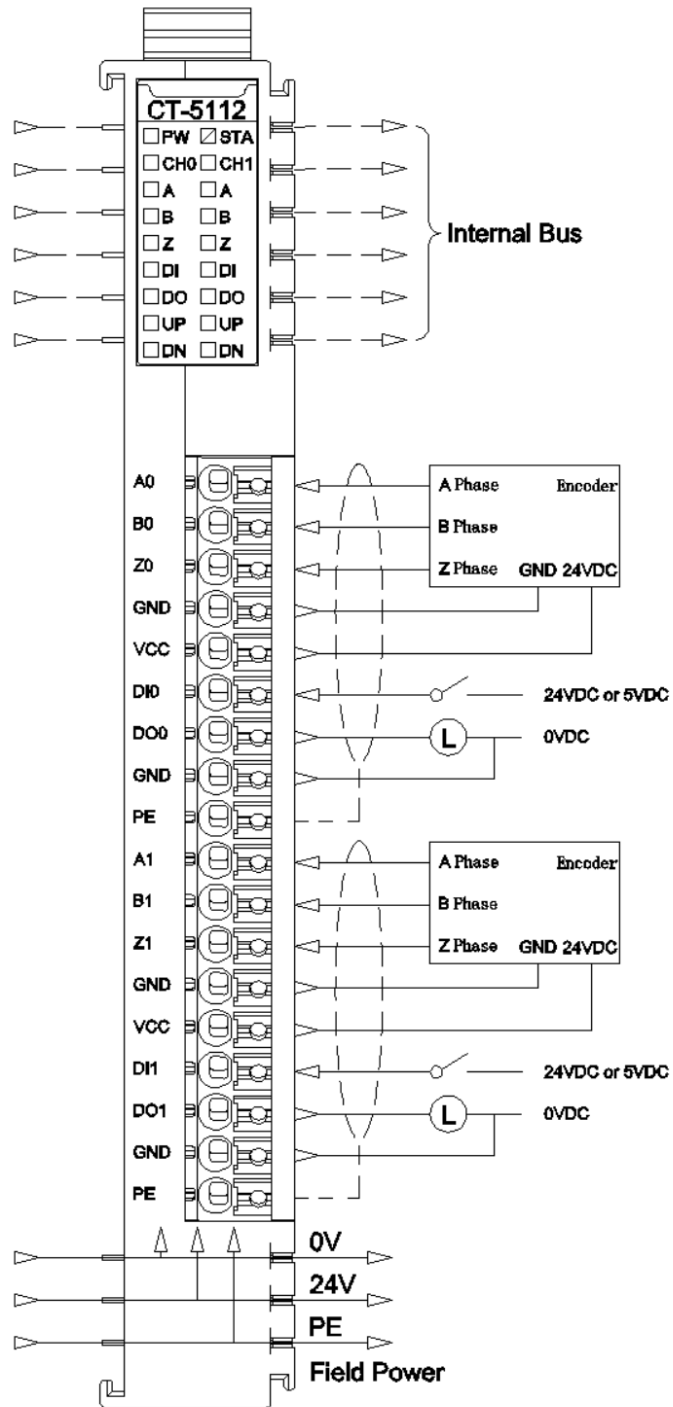

5 Process data definition

< 2 Analog Input(24V Encoder) > Submodule process data definition

Input Data								
Bit No	Bit 7	Bit 6	Bit 5	Bit 4	Bit 3	Bit 2	Bit 1	Bit 0
Byte 0	Counter DOWN Ch#0	Counter UP Ch#0	Counter Underflow Ch#0	Counter Overflow Ch#0	DI Ch#0	Z Ch#0	B Ch#0	A Ch#0
Byte 1	Reserved							
Byte 2	Counter DOWN Ch#1	Counter UP Ch#1	Counter Underflow Ch#1	Counter Overflow Ch#1	DI Ch#1	Z Ch#1	B Ch#1	A Ch#1
Byte 3	Reserved							
Byte 4	Counter value Ch#0							
Byte 5								
Byte 6								
Byte 7								
Byte 8	Capture value Ch#0							
Byte 9								
Byte 10								
Byte 11								
Byte 12	Measurements 1 Ch#0							
Byte 13								
Byte 14								
Byte 15								
Byte 16	Measurements 2 Ch#0							
Byte 17								
Byte 18								
Byte 19								
Byte 20	Counter value Ch#1							
Byte 21								
Byte 22								
Byte 23								
Byte 24	Capture value Ch#1							
Byte 25								
Byte 26								
Byte 27								
Byte 28	Measurements 1 Ch#1							
Byte 29								
Byte 30								
Byte 31								
Byte 32	Measurements 2 Ch#1							
Byte 33								
Byte 34								
Byte 35								
Output Data								
Bit No	Bit 7	Bit 6	Bit 5	Bit 4	Bit 3	Bit 2	Bit 1	Bit 0

Byte 0	Reserved	Flow Clear Ch#0	Counter Set Trigger Ch#0	DO Ch#0
Byte 1	Reserved			
Byte 2	Reserved	Flow Clear Ch#1	Counter Set Trigger Ch#1	DO Ch#1
Byte 3	Reserved			
Byte 4	Set Value for Counter Ch#0			
Byte 5				
Byte 6				
Byte 7				
Byte 8	Set Value for Counter Ch#1			
Byte 9				
Byte 10				
Byte 11				

Data Declaration:

Input data definition:

A/B/Z Ch#(0-1): The position is 1 when the corresponding channel A/B/Z input signal is valid, and 0 when the input is invalid.

DI Ch#(0-1): Digital input signal status.

Counter Overflow Ch#(0-1): Counter overflowed flag bit.

Counter Underflow Ch#(0-1): Counter underflows flag bit.

Counter UP: Encoder positive rotation, counter up counting sign.

Counter DOWN: Encoder contrarotation, counter down count flag.

Counter Value Ch#(0-1): Pulse count value, 32 - bit signed integer, automatically clear after overflow.

Capture value Ch#(0-1): Pulse capture value, 32-bit signed integer, and when DI is set to capture, the pulse count value will be captured to the capture value at the selected edge.

Measurements 1 Ch#(0-1): Measurement value 1, the measurement value will be output according to the measurement value type selected by the user (view the configuration parameter section of the module for optional measurement value)

Measurements 2 Ch#(0-1): Measurement value 2, the measurement value will

be output according to the measurement value type selected by the user (view the configuration parameter section of the module for optional measurement value)

Output data definition:

DO Ch#(0-1): Digital output channel control.

Counter Set Trigger CH#(0-1): Counter set trigger bit, rising edge trigger counter set, the output value **Set Value for Counter** will be updated to **Counter Value**, this function can be used to set the initial value of the counter.

Flow Clear CH#(0-1): Overflow clear bit, the rising edge can clear the input **Counter Overflow** and **Counter Underflow** flag bits.

Set Value for Counter Ch#(0-1): Counter set value.

6 Configuration parameters definition

<2 Analog Input(24V Encoder)> Submodule configuration parameter definition

Configuration Parameter								
Bit No	Bit 7	Bit 6	Bit 5	Bit 4	Bit 3	Bit 2	Bit 1	Bit 0
Byte 0	Reserved					16Bit Data Format	32Bit Data Format	
Byte 1	Reserved					Work Mode Ch#0		
Byte 2	Reserved					Frequency Multiplication Ch#0		
Byte 3	Reserved		Filtering Time Ch#0					
Byte 4	Reserved						Counter Storage Ch#0	
Byte 5	Reserved					Encode Output Signal Type Ch#0		
Byte 6	Reserved						DI Function Selection Ch#0	
Byte 7	Reserved					Capture Mode Ch#0		
Byte 8 ... Byte 17	Reserved							
Byte 18	Reserved					Speed Measurement Time Ch#0		
Byte 19	Reserved	Measurements 2 Type Ch#0				Measurements 1 Type Ch#0		
Byte 20	Encoder Resolution Ch#0							
Byte 21								
Byte 22	Transmission Ratio Active Ch#0							
Byte 23								
Byte 24	Transmission Ratio Slave Ch#0							
Byte 25								
Byte 26 ... Byte 33	Reserved							
Byte 34	Reserved					Work Mode Ch#1		
Byte 35	Reserved					Frequency Multiplication Ch#1		

Byte 36	Reserved	Filtering Time Ch#1	
Byte 37	Reserved		Counter Storage Ch#1
Byte 38	Reserved		Encode Output Signal Type Ch#1
Byte 39	Reserved		DI Function Selection Ch#1
Byte 40	Reserved		Capture Mode Ch#1
Byte 41 ... Byte 50	Reserved		
Byte 51	Reserved		Speed Measurement Time Ch#1
Byte 52	Reserved	Measurements 2 Type Ch#1	Measurements 1 Type Ch#1
Byte 53 Byte 54	Encoder Resolution Ch#1		
Byte 55 Byte 56	Transmission Ratio Active Ch#1		
Byte 57 Byte 58	Transmission Ratio Slave Ch#1		
Byte 59 ... Byte 66	Reserved		

Data Declaration:

16Bit Data Format: Byte transfer order of channel state. (Default: 0)

0: A-B

1: B-A

32Bit Data Format: The byte transfer order of a channel count value. (Default: 0)

0: AB-CD

1: BA-DC

2: CD-AB

3: DC-BA

Work Mode Ch#(0-1): Working mode of encoder. (Default: 0)

- 0: Incremental encoder mode.
- 1: Count direction mode.
- 2: Count up mode.
- 3: Count down mode.

Frequency Multiplication Ch#(0-1) : Frequency multiplication number (available only in incremental encoder mode), according to this mode it could output pulse count value. (Default: 2)

- 0: frequency multiplication 1
- 1: frequency multiplication 2
- 2: frequency multiplication 4

Filtering Time Ch#(0-1): Encoder input filter time (default: 5)

- 0: no filter
- 1: 0.1uS
- ...
- 5: 0.5 uS
- ...
- 31: 3.1 uS

Counter Storage Ch#(0-1): Enable storage. When the storage function is enabled, the IO module will save the count value to the non-volatile memory in real time, and load the last saved count value at the next power-on. (Default: 1)

- 0: Disable
- 1: Enable

Encoder Output Signal Type Ch#(0-1): Encoder output type (default: 0)

- 0: Source
- 1: Sink
- 2: Push-pull

DI Function Selection Ch#(0-1): DI function selection (Default: 0)

- 0: Normal DI function
- 1: Pulse capture function

Capture Mode Ch#(0-1): Capture mode (default: 0)

- 0: Rising edge capture
- 1: Falling edge capture
- 2: Double edge capture

Speed Measurement Time Ch#(0-1): Speed measurement period (Default: 6)

- 0: 10mS
- 1: 20mS
- 2: 50mS
- 3: 100mS
- 4: 200mS
- 5: 500mS
- 6: 1000mS
- 7: 2000mS

Measurements 1 Type Ch#(0-1): Measurement value 1 Type selection (default: 0)

- 0: No measurements
- 1: Measuring speed (min/rotation)
- 2: Measuring frequency

Measurements 2 Type Ch#(0-1): Measurement value 2 Type selection (default: 0)

- 0: No measurements
- 1: Measuring speed (min/ rotation)
- 2: Measuring frequency

Encoder Resolution Ch#(0-1): Encoder resolution (default: 1)

Value range: 1-65535

Transmission Ratio Active Ch#(0-1): 1) Transmission ratio (main) (Default: 1)

Value range: 1-65535

Transmission Ratio Slave Ch#(0-1): Transmission ratio (main) (Default: 1)

Value range: 1-65535

A Dimension drawing

